

HWM3060

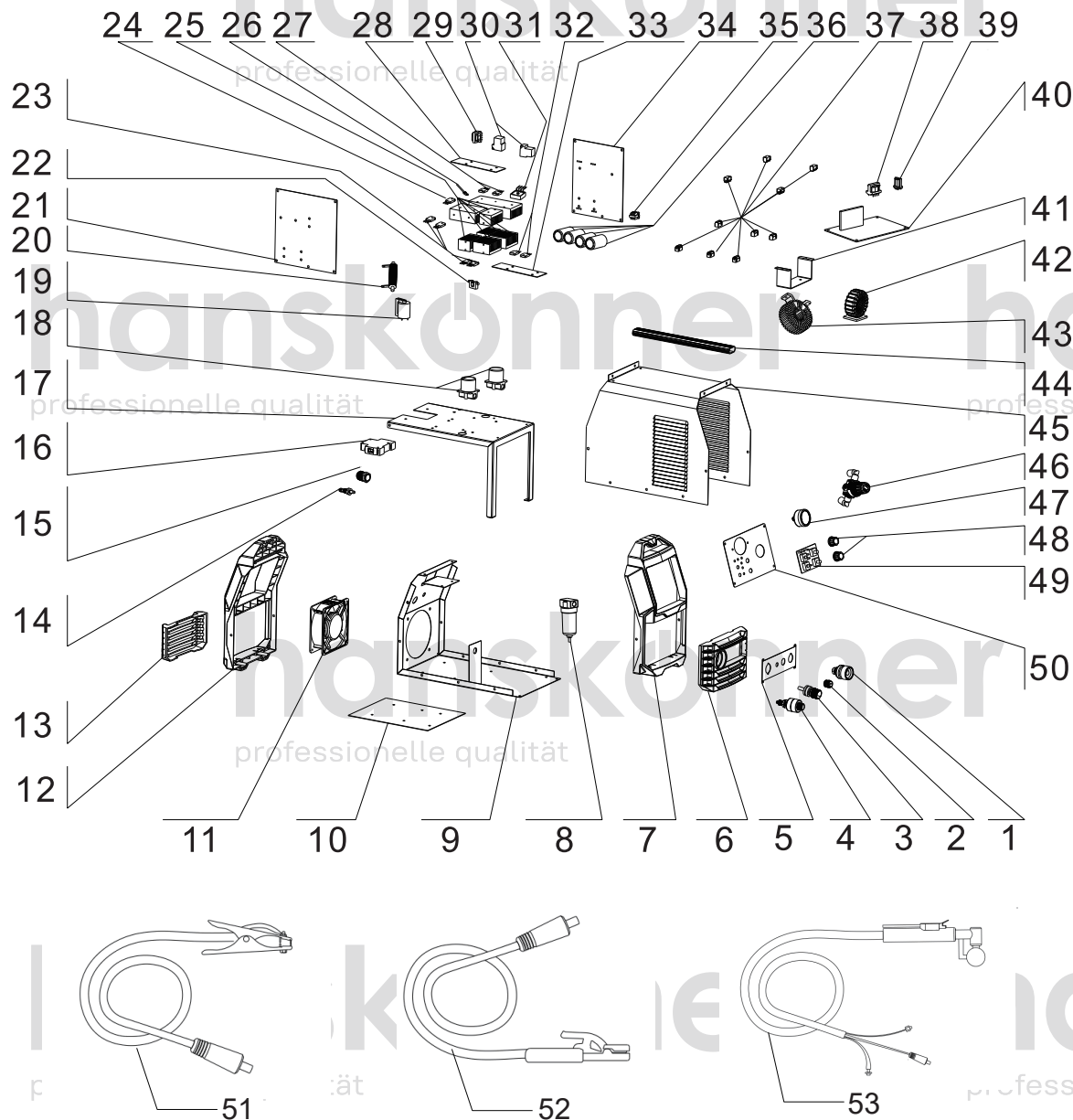

No	Description	No	Description
1	Fast connector 35-50mm	26	NPC
2	Torch's switch socket	27	IGBT 60U65
3	Pilot arc wire socket	28	Epoxy resin plate
4	Gas-electric integrated socket	29	Driver Transformer
5	Big front of panel	30	Relay 30A
6	Small front of panel	31	Rectifier bridge 60A
7	Front of plastic panel	32	IGBT 60U65
8	Oil water diverter	33	Epoxy resin plate
9	Bottom case	34	PBM -85B assembled pc board
10	Epoxy resin plate	35	Transducer
11	Fan high speed	36	Capacitor 560UF400V
12	Big back of panel	37	Foot pad for circuit board
13	Small back of plastic panel	38	Transformer
14	Gas inlet socket	39	Transformer
15	ower cord anchorage	40	PKB-73 PWM board
16	Air switch	41	Metal of support
17	Median septum	42	Reactance
18	Magnetic valve	43	Main Transformer
19	FBT	44	Metal of handle
20	Arc striking coil	45	Beside housing
21	PDB-25 circuit board	46	Pressure regulating valve
22	Arc device	47	Gas-pressure meter
23	Fast recovery diode	48	Knob
24	Pilot arc IGBT 60U65	49	Front of circuit board
25	Radiator (set)	50	Front of metal panel
		51	Earth Clamp with cable
		52	Eelectrode holder with cable
		53	P80 Plasma cutting torch

HWM3060-EX-RUS220823

HWM3060 FRONT-BOARD

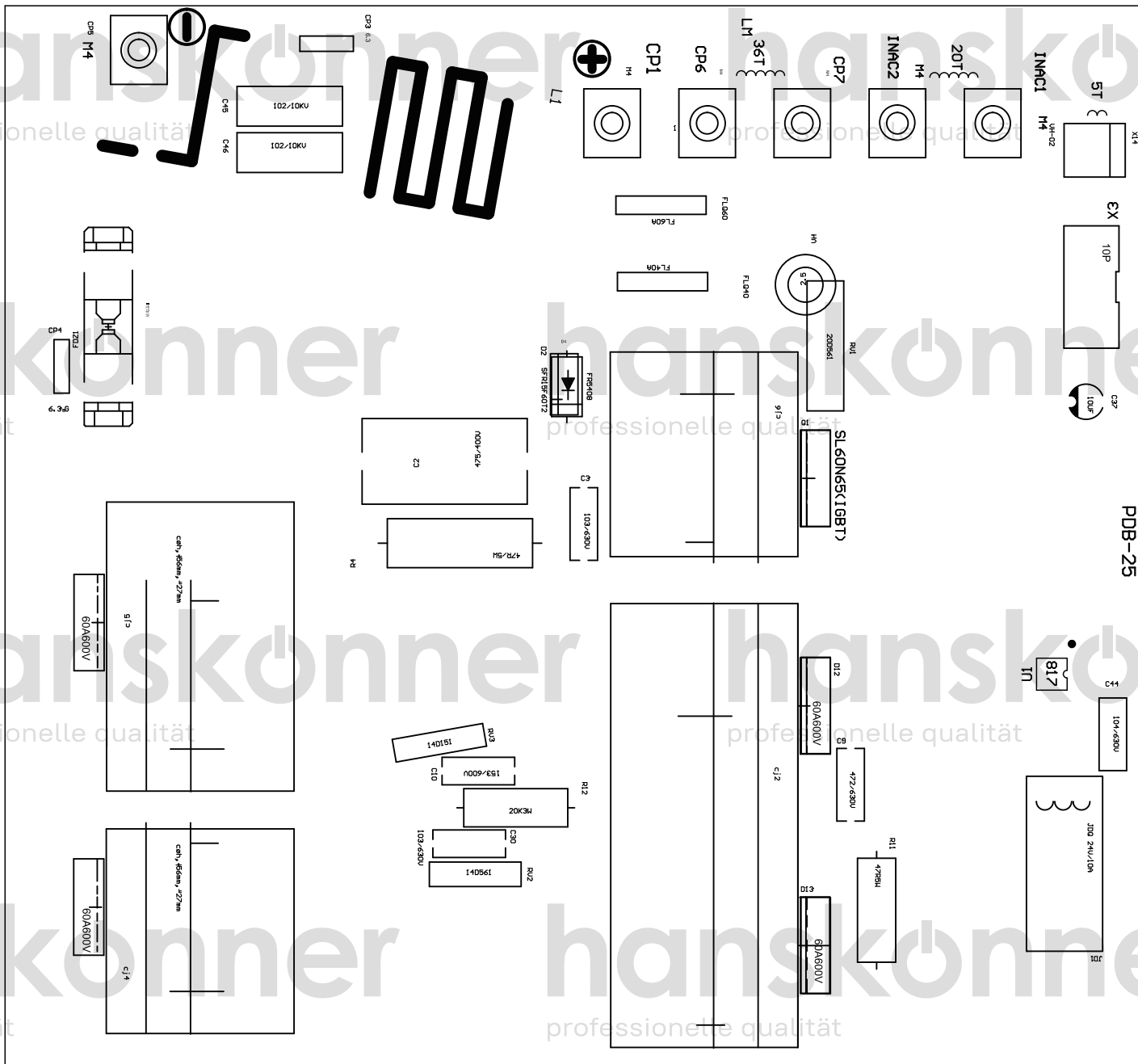

HWM3060 MAIN-BOARD

